



## High sensitivity altitude control valve with two set points Mod. XLC 370/470-D

The CSA Model XLC 370/470-D is a globe pattern hydraulically operated automatic valve that regulates the water level of a reservoir and water tower within a minimum and maximum value, regardless of upstream pressure variations. The modulating control ensures a smooth regulation and absence of water hammer. Normally equipped with visual position indicator, and entirely made in ductile cast iron with FBT epoxy coating and stainless steel, the valve is designed to reduce head loss, throttling noise and cavitation damage.

### Applications

- To perform the level control of elevated tanks and water towers with a minimum and maximum range.
- Through the high sensitivity pilot to control the water level, without accessing the tank and the need of any extra piping.
- On the tank and reservoirs outlet supply lines to control the consumption by means of the storage static pressure working on a specific range pre-set and adjustable through the minimum and maximum pilots.

### Accessories

- Linear position transmitter with 4-20 mA output Mod. CSA CSPL.
- On-off position transmitter Mod. CSA CSPO.
- Pressure measurement kit.
- Self-flushing and high capacity filter.

### Note to the engineer

- Inlet pressure, outlet pressure, flow rate and application are required for the proper sizing.
- For the proper functioning a minimum of 0,3 bar static value acting on the pilot is needed. Consider the use of a sustaining pilot for low pressure conditions and/or the CSA CSFL mechanical flow regulator.

### Additional features

- XLC 370/470-FR altitude automatic control valve with back-flow prevention.
- XLC 427 upstream pressure sustaining and altitude control valve.
- XLC 427-5 altitude automatic control valve with on-off solenoid control.
- The valve can be supplied without the regulation device GR.I.F.O. on request.

### Working conditions

- Fluid: treated water.
- Min. operating pressure on the valve: 0,7 bar.
- Minimum static pressure on the pilot: 0,3 bar.
- Max. operating press.: 16 bar.
- Recommended working pressure: 6 bar. Higher on request.
- Maximum temperature: 70°C.

### Altitude pilot adjustment range

- Blue spring: 0,3 to 1,8 bar.
- Red spring: 0,6 to 2,8 bar.
- Different values on request.

## Operating principle

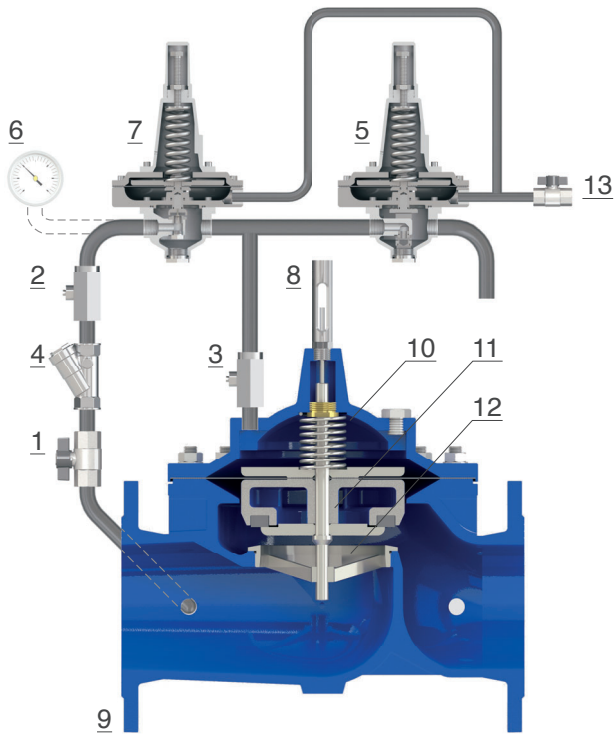

The CSA Model XLC 370/470-D is operated by two high sensitivity pilots (5 and 7) sensing the static pressure of the level in need of regulation through a port (13). Should the level inside the tank rise above the maximum set point the pilot (7) will open diverting the flow towards the chamber (10) closing the valve. The valve will remain closed until the water level drops, due to consumption, to the minimum value at which the pilot (5) will open, relieving pressure out of the main chamber (10) thus lifting the obturator upwards (11) to generate flow through the seat and refill the storage. Pressure in and out of the main chamber (10) is controlled by the CSA exclusive needle valve (3) to ensure smooth operation and the absence of unwanted pressure surges.

## Installation layout

Level control is obtained without any external piping and simply through a pilot sensing the static pressure coming from the water tower. The lay-out includes sectioning devices (1, 2) and by-pass, where CSA automatic control valves (4) are advised, for maintenance operations, and a filter (3) to prevent dirt from entering the main valve. Anti-surge combination air valves FOX 3F AS (5) are recommended upstream to release air pockets accumulated in working conditions, and to discharge large volumes of air during filling.

