

Upstream pressure sustaining constant level control valve Mod. XLC 326/426

The CSA Model XLC 326/426 is a globe pattern hydraulically operated automatic control valve that sustains the upstream pressure to a minimum value and at the same time regulates the constant level of a tank, regardless of upstream pressure variations. Thanks to a needle valve on the chamber the response time can be adjusted, to prevent water hammer effects during the closing phase. Normally equipped with visual position indicator and entirely made in ductile cast iron with FBT epoxy coating and stainless steel, the valve is designed to reduce head loss, throttling noise and cavitation damage.

Applications

- For break pressure tanks and when a proportional level control is needed within the pilot's range.
- For level control on gravity fed pipelines.
- For small tank and in need of maintaining a constant level with a continuous modulating without excessive drop in pressure.

Accessories

- On-off position transmitter Mod. CSA CSPO.
- Pressure measurement kit.
- Self-flushing and high capacity filter.
- CSA anti-cavitation low flow stability plugs are recommended to provide an accurate regulation in case of low flow conditions.
- CSFL mechanical flow regulator.

Note to the engineer

- Avoid bends and high points on the piping to connect the main valve to the level control pilot to prevent the formation of air pockets.
- For the proper functioning a minimum of 1 bar on the level control pilot is needed, failing in doing so would create delays and malfunctioning.

Additional features

- XLC 326/426-FR pressure sustaining and constant level valve with back-flow prevention.
- XLC 326/426-R pressure sustaining and constant level valve with surge prevention pilot.

Working conditions

- Fluid: treated water.
- Minimum operating pressure: 1 bar on the level control pilot.
- Maximum operating pressure: 16 bar.
- Recommended working pressure: 6 bar. Higher on request.
- Maximum temperature: 70°C.

Upstream pressure pilot adjustment range

- Blue spring: 0,7 to 7 bar.
- Red spring: 1,5 to 15 bar.
- Higher values up to 25 bar on request.

Constant level pilot adjustment range

- 85 mm as a standard, different on request.

Operating principle

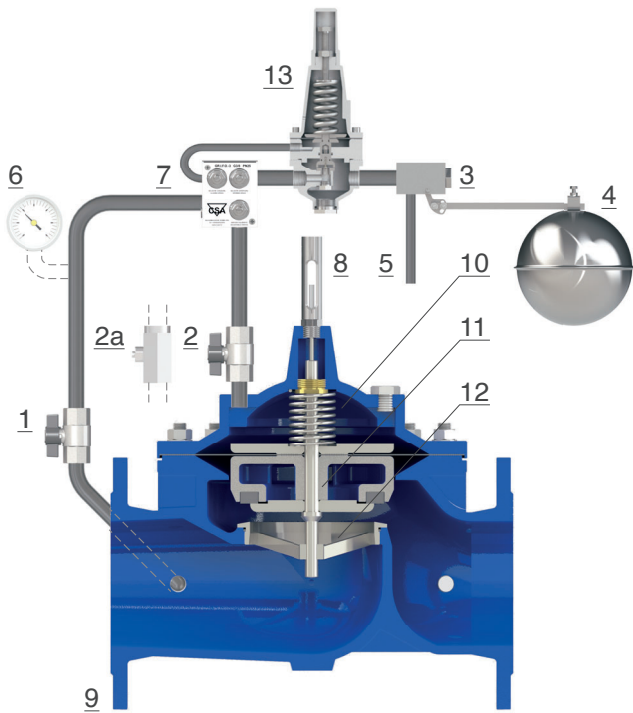

The CSA model XLC 326/426 is operated by two pilots in series where the first is the (13) pressure sustaining unit followed by a control level proportional pilot (3). The first (13) will open in case of incoming pressure higher than the set point, closing and diverting flow towards the chamber (10), should the upstream pressure fall below the set point. If the level drops inside the tank due to consumption the proportional pilot (3) will open through the drain (5) discharging the main chamber (10), to generate a passage through the seat (12) in proportion to the demand, lifting the obturator (11) upwards accordingly. Should the tank level rise due to the refilling the pilot (3) will modulate, throttling the flow through the drain (5) and, if required, closing the valve. The water flow goes in and out of the chamber (10) through the exclusive unit flow control device GR.I.F.O. (7), provided with three adjustable needles valves and check valves for the regulation of the opening and closing speed, independently of one another, needed for the valve's response time and accuracy.

Installation layout

The XLC 326/426 is linked to the level pilot (2) through a single pipe. Sectioning devices (1) are recommended for maintenance and a filter (3) is needed upstream, to prevent dirt from entering the main valve, affecting the performance. The constant level control pilot (2) should always be located in a position away from the water surface turbulence created by the inlet supply pipe to the tank. In case of static values higher than 6 bar the AC (anti-cavitation) system and a CSA pressure reducer VRCD are advised.

