



Pressure relief/sustaining valve for high temperatures - Mod. VSM ST

The CSA direct acting upstream pressure relief/sustaining valve Mod. VSM ST automatically maintains and sustains a pre-set upstream pressure, discharging any excess downstream, regardless of variations in demand and downstream pressure fluctuations.



Technical features and benefits

- Flanged version DN 50-150.
- Upstream pressure balanced, to stabilize and maintain the upstream pressure to a minimum pre-set (and adjustable) value regardless of demand and downstream pressure variations.
- Ductile cast iron for body and cap, piston in stainless steel, seat in stainless steel, guiding bush in stainless steel as well as bolts and nuts.
- Innovative self cleaning piston technology (patent pending) to improve performances reducing maintenance operations.
- Mobile block composed of three components in gun metal/stainless steel obtained by CNC to ensure the maximum accuracy and sliding precision, this is to avoid friction and unexpected leakage.
- Upstream/downstream pressure outlets for gauges.
- Large expansion chamber to reduce noise and to provide an excellent resistance to cavitation.
- Body and cap nickel-plated for high temperatures.

Applications

- Industrial plants.
- Heating systems.
- Process plants.
- Buildings and civil installations in general.

Operating principle

The operating principle of VSM ST is based on a piston sliding into two rings in stainless steel/bronze of different diameters. These rings, tightly connected to the body, form a watertight chamber also known as the compensation chamber.

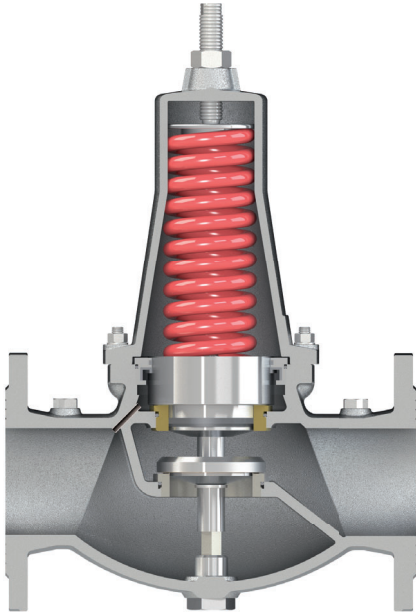

Valve normally closed

Without any incoming pressure the VSM ST is a normally closed valve, as shown in the picture, where the obturator is kept pushed down to the seat by the force of the spring.

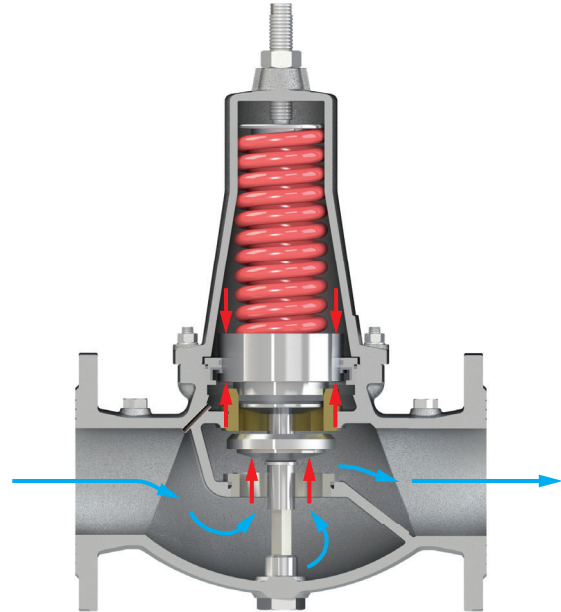

Valve fully open

Should the upstream pressure rise above the set point of the valve, obtained by the compression of the spring, the VSM ST will open completely allowing the full passage through the seat.

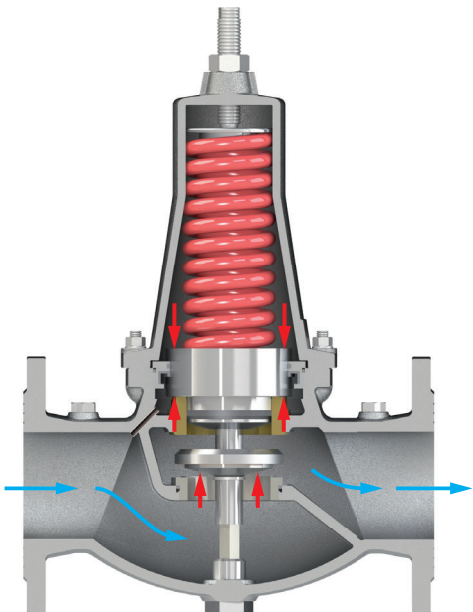

Valve modulating

Should the upstream pressure fluctuate around the valve's set point, the obturator, thanks to the difference in force between the spring pushing downwards and the incoming pressure underneath and through the compensation chamber pushing upwards, will move throttling the flow through the seat in order to maintain the minimum required value.

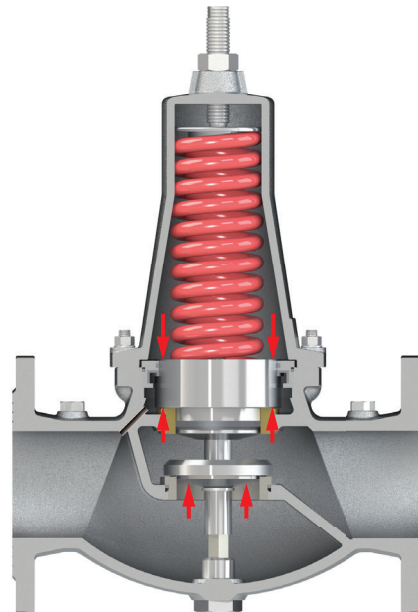

Valve fully closed (static conditions)

Should the water supply be interrupted from upstream pressure begins to drop, in this case the VSM ST will react immediately to maintain and stabilize the required upstream pressure even with no flow thanks to the pressure balanced technology and compensation chamber.

Technical data

DN mm	50	65	80	100	125	150
Kv (m ³ /h)/bar	22	51	83	122	166	194

Head loss coefficient

Kv coefficient representing the flow rate which is flowing through the valve fully open producing a head loss of 1 bar.

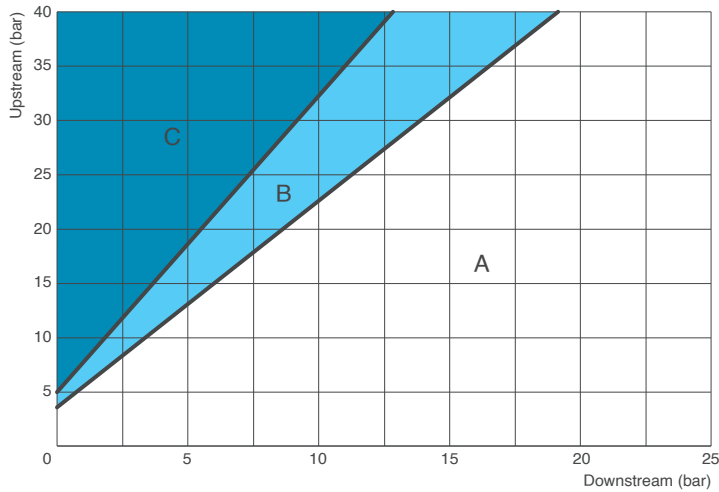

Cavitation chart

- A: Recommended working conditions;
- B: Incipient cavitation;
- C: Damage cavitation.

Ensure that the working point, obtained connecting upstream (y axis) and downstream (x axis) pressure conditions, falls on the A zone with the smallest valve to meet the required flow. The chart is to be used for valves modulating with an opening percentage between 35-40% at standard water temperature and elevation below 300 m. For continuous pressure sustaining the maximum allowed DP shall not exceed 17 bar. The pressure relief function will tolerate higher pressure differential values.

Working conditions

Treated water/air temperature: max. 100°C.

Maximum working pressure 40 bar.

Upstream pressure values: from 1,5 to 6 bar or from 5 to 12 bar.

Higher values on request.

Standard

Certified and tested in compliance with EN 1074/5.

Flanges according to EN 1092/2.

Body and cap nickel-plated.

Changes on flanges and coating available on request.

Recommended flow rate - pressure sustaining

DN (mm)	50	65	80	100	125	150
Flow rate min. (l/s)	0,4	0,6	0,9	1,4	2,2	3,2
Flow rate max. (l/s)	4,5	7,6	11	18	28	40

Recommended flow rate - pressure relief

DN (mm)	50	65	80	100	125	150
Flow rate max. (l/s)	8,8	14	22	35	55	79

Weights and dimensions

DN (mm)	50	65	80	100	125	150
A (mm)	230	290	310	350	400	480
B (mm)	83	93	100	110	135	150
C (mm)	280	320	350	420	590	690
Weight (Kg)	12	19	24	34	56	74

Values are approximate, consult CSA service for more details.

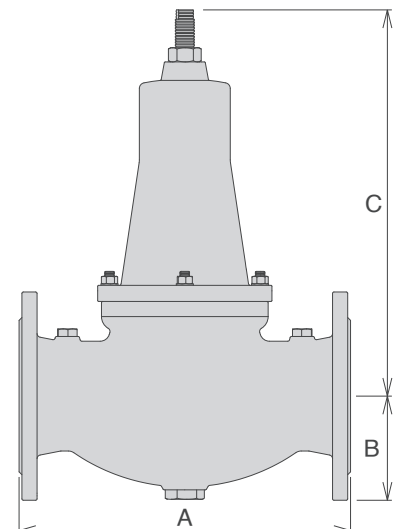

Technical details

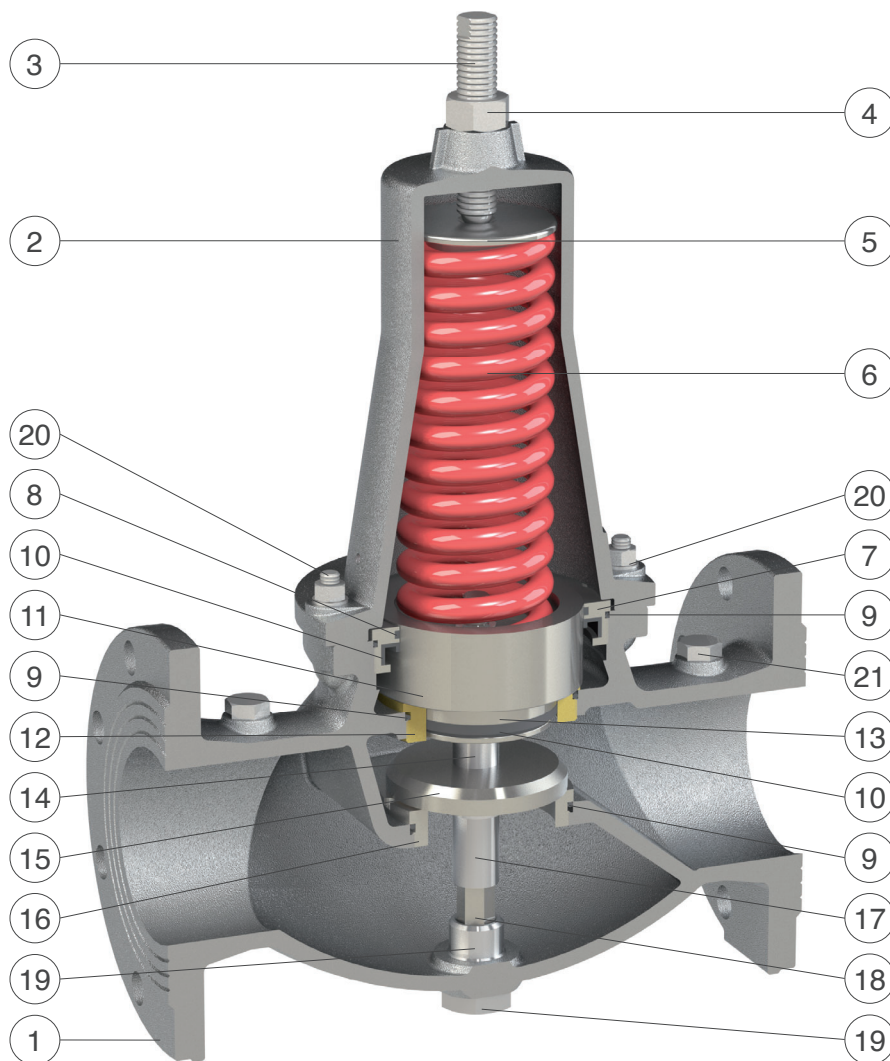

N.	Component	Standard material	Optional
1	Body	nickel-plated ductile cast iron GJS 450-10	
2	Cap	nickel-plated ductile cast iron GJS 450-10	
3	Driving screw	stainless steel AISI 304	stainless steel AISI 316
4	Nut	stainless steel AISI 304	stainless steel AISI 316
5	Spring guide	stainless steel AISI 303	stainless steel AISI 316
6	Spring	spring painted steel 52SiCrNi5	
7	Main bush	stainless steel AISI 304	stainless steel AISI 316
8	Sliding ring	PTFE	
9	O-rings	Viton	
10	Gasket	Viton	
11	Upper piston	st. st. AISI 303 (bronze CuSn5Zn5Pb5 for DN 125-150)	stainless s. AISI 303/316
12	Lower reinforcements	bronze CuSn5Zn5Pb5	stainless s. AISI 304/316
13	Lower piston	stainless steel AISI 303	stainless steel AISI 316
14	Central spacer	stainless steel AISI 303	stainless steel AISI 316
15	Obturator with plane gasket	st. st. AISI 303 and Viton	stainless steel AISI 316
16	Obturator sealing seat	stainless steel AISI 304	stainless steel AISI 316
17	Lower spacer	stainless steel AISI 303	stainless steel AISI 316
18	Guiding shaft	stainless steel AISI 303	stainless steel AISI 316
19	Driving tap	stainless steel AISI 303	stainless steel AISI 316
20	Studs, nuts and washers	stainless steel AISI 304	stainless steel AISI 316
21	Taps for pressure gauges	stainless steel AISI 316	

The list of materials and components is subject to changes without notice.