

Flow rate automatic control valve Mod. XLC 330/430



The CSA model XLC 330/430 is a globe pattern hydraulically operated automatic control valve that limits the flow to a pre-set value, regardless of pressure variations. In case of flow rate lower than the required set point the valve will be fully opened. The valve is supplied with an orifice plate assembly, needed for the proper functioning and connected to the pilot. Normally equipped with visual position indicator and entirely made in ductile cast iron with FBT (fluid bed technology) epoxy coating and stainless steel, the valve is designed to reduce head loss, throttling noise and cavitation damage.

Applications

- Downstream of pumps to prevent overload and for cavitation protection.
- On the inlet supply lines of tanks to prevent excessive flow.
- In distribution networks and on the supply lines of residential and industrial districts to limit the flow during peak hours.
- In filtration systems to prevent excessive flow avoiding damages and malfunctioning.

Accessories

- Linear position transmitter with 4-20 mA output Mod. CSA CSPL.
- On-off position transmitter Mod. CSA CSPO.
- Pressure measurement kit.
- Self-flushing and high capacity filter.

Note to the engineer

- Inlet and outlet pressure, flow rate are required for the proper sizing.
- CSA anti-cavitation low flow stability plugs are recommended to provide an accurate regulation in case of low flow conditions.
- For the best accuracy leave 5 DN between the valve and the orifice plate and 3 DN downstream of it (picture in the next page).

Additional features

- XLC 330/430-FR flow rate control valve with back-flow prevention.
- XLC 330/430-H flow rate control valve with high sensitivity pilot.

Working conditions

- Fluid: treated water.
- Minimum operating pressure: 1,2 bar.
- Maximum operating pressure: 16 bar. Higher on request.
- Maximum temperature: 70°C.

Flow rate control pilot adjustment range

- The orifice plate assembly is calculated and machined according to the maximum flow rate. An adjustment range of the value is possible according to the regulation flow chart supplied with the valve.

Operating principle

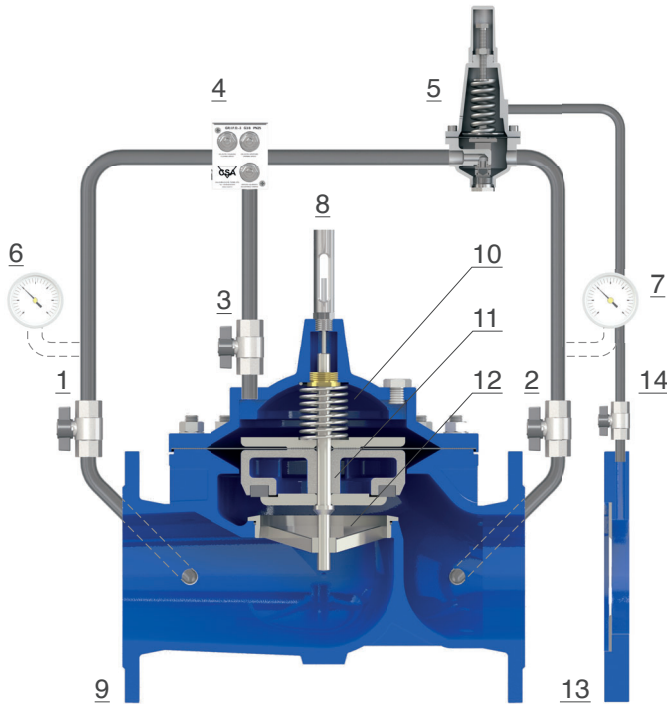

The CSA model XLC 330/430 is operated by a two ways pilot (5), for flow control, with pre-set set and adjustable values, sensing the drop in pressure produced by the orifice plate (13), where a stainless steel disk is inserted inside a flange and connected to the pilot with a sensing line (14) non supplied.

Should the flow exceed the maximum value the differential pressure will increase and pilot (5) will throttle and limit the flow to direct inlet pressure to the main chamber (10), to generate the head loss required through the seat (12) for the valve (9) to control the flow. Should the flow remain below the pilot's set point, the differential pressure across the orifice plate (13) will be less than the pilot's (5) spring force, therefore the valve will remain fully open.

Pressure in and out of the main chamber (10) is controlled by the CSA exclusive regulation device with filter called GR.I.F.O. (4), needed for the valve's response time and accuracy.

Installation layout

The picture shows the recommended lay-out of the CSA XLC 330/430. The flange orifice (8), calculated and machined according to the project's requirements, is connected to the valve's pilot (9). Sectioning devices (1, 2) and by-pass are very important for maintenance operations, as well as the filter (3) to prevent dirt from reaching the control valve. Anti-surge combination air valves FOX 3F AS (6, 7) are recommended, as well as a pressure relief valve, like CSA VSM (5) to prevent rise in pressure on the main line.

